

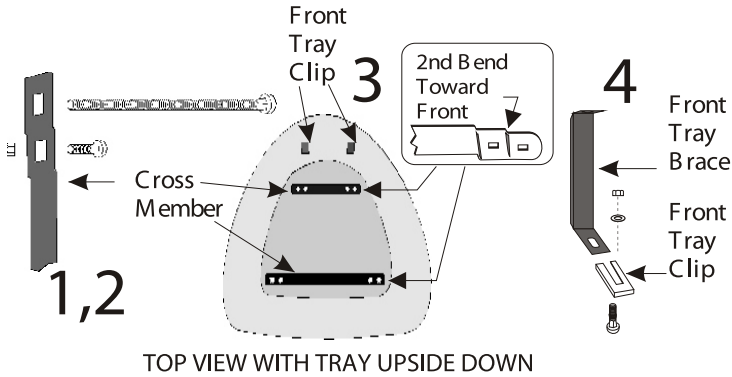

1015/1018 Series Instructions

Steel Handled Contractor

Hardware

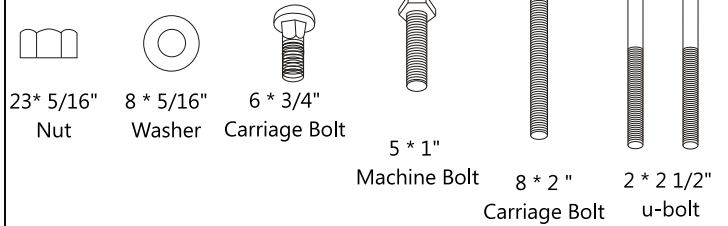

1. Install 3/4" carriage bolts and nuts loosely through the inner slots of the cross braces. Insert 2" bolts, without nuts through the outer slots of the cross braces.
2. Slide the cross braces onto the tray clips, with the heads of the 3/4" bolts in the clips, secure finger tight.
3. Install 3/4" carriage bolts and nuts loosely through the slots of the tray braces, use the rounded end of the tray brace. Slide the tray braces onto the clips on the front of the tray.

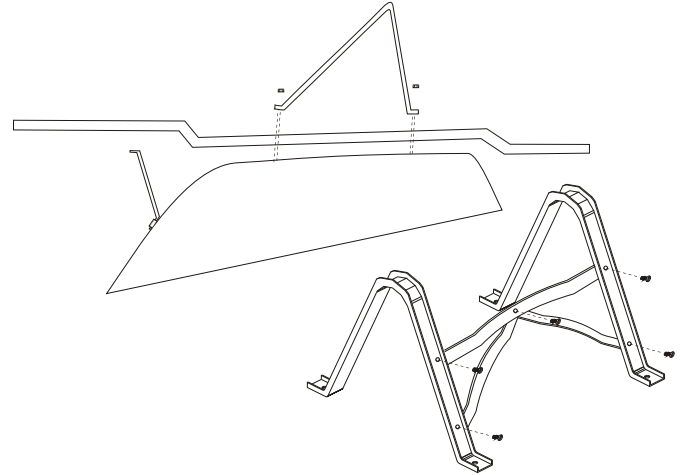

1. Moisten the inside of each handle grip with water and slide over end of the handle, the end without holes.
2. Place each handle on the 2" bolts attached to the cross braces, note handle bends.
3. Place each leg over the bolts on the handles, the holes on the legs should face the rear of the tray, secure loosely with nuts.
4. Attach the leg braces with 1" machine bolts and nuts.

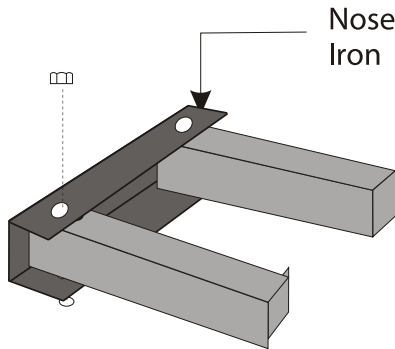

1. Attach the nose iron using 2" carriage bolts, nuts and washers.
2. Attach the tray braces to the handle using 2" bolts, nuts and washers.
3. All nuts can be tightened now using a 1/2" wrench.

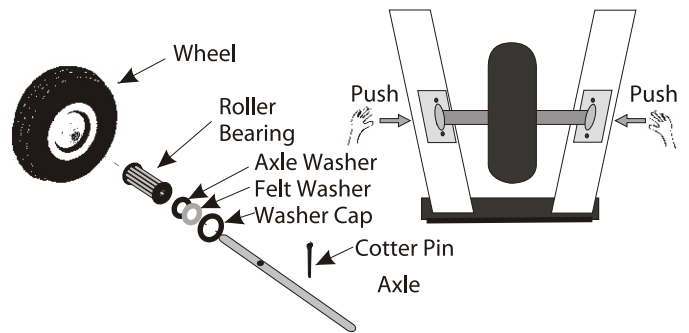

1. Place u-bolt through both axle boxings. Place one u-bolt and axle boxing on the handle.
2. Remove one cotter pin and one outer large washer from the axle bearing assembly. Slide the unit through the wheel hub and replace the washer and cotter pin. Bend both cotter pins with a hammer or pliers to secure them.
3. Slide the axle into the u-bolts and secure u-bolts with nuts and washers.



Any problems please call us.

www.SinclairErie.com 37 Pacific Ave.
 Phone: 866-316-3743 Milverton, On.
 Fax: 866-316-4941 NOK 1M0